





# SAFETY PRECAUTIONS



WARNING:

## 安全にお使いいただくために

危険や損害の大きさと切迫の程度を明示するために、誤った扱いをすると生じることが想定される内容を次の定義のように「警告」「注意」の二つに区分しています。



**警告:** この表示内容が無視して誤った取り扱いをすると、死亡または重傷を負う可能性が想定される内容です。



### 警告

- 水や異物が入ると火災や感電の原因となります。
- 本製品の改造は試みないでください。改造した場合には怪我や製品故障の原因となります。



**注意:** この表示内容が無視して誤った取り扱いをすると、傷害を負う可能性または物的損害が発生する可能性が想定される内容です。



### 注意

- 分解・改造は故障の原因となりますので絶対におやめください。
- 無理な力を与えたり、ケーブルを引っ張ったりしないでください。故障の原因となります。
- マイクホンは濡らさないようにしてください。極度の高温・低温や湿気にさらさないでください。









“เครื่องโทรคมนาคมและอุปกรณ์นี้ มีความสอดคล้องตามข้อกำหนดของ กทช.”

## Pengaturan Cepat

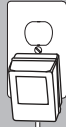
1

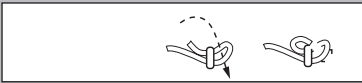

2



3

# Shure SVX Wireless

Receiver



Transmitter

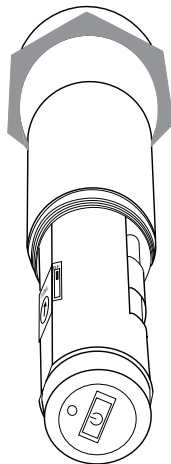

## System Components

All Systems

Bodypack Transmitter

Handheld Transmitter

OR

## Power

## Connecting to a Sound System

## Channel

Bodypack Gain

RF Level

Squelch

Color ID Rings

G

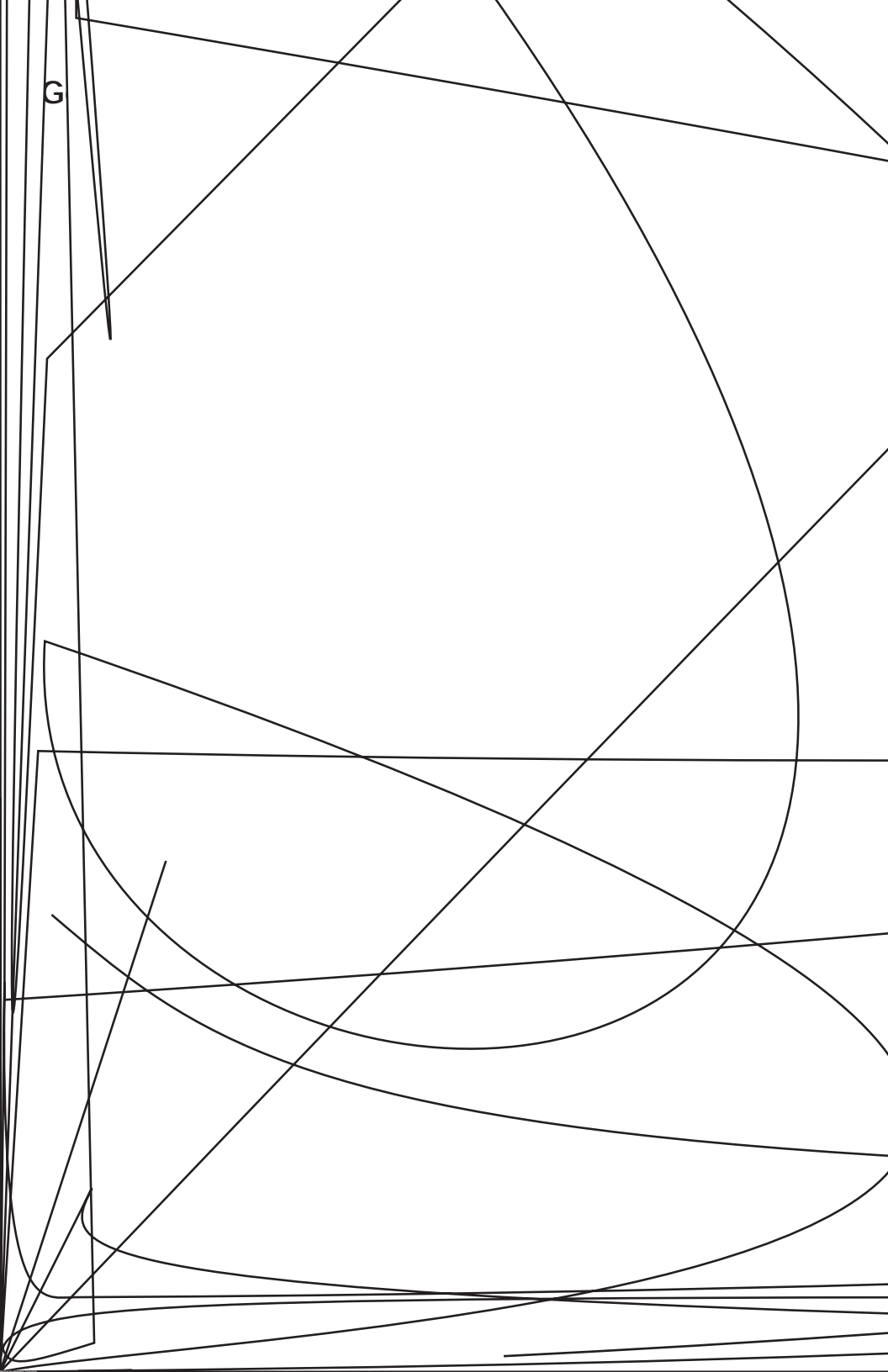



# Wireless Tips to Improve System Performance

## Troubleshooting

Problem	Solution
No sound	
Noise from RF interference	
Audio distortion	



# SVX

Working Range	HI power mode: LO power mode:
Audio Frequency Response	
Total Harmonic Distortion	
Dynamic Range	

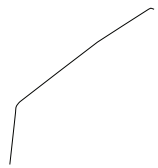

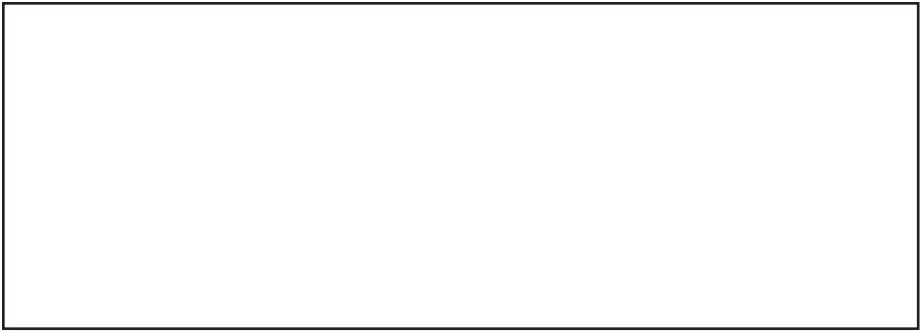









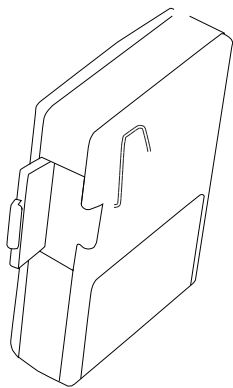

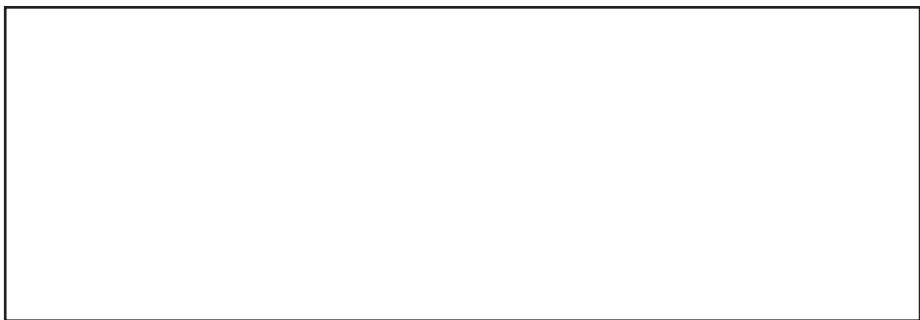



WACR

WASRM

WADRM

53A14226

95A14227

P12	698-710
P14	710-726
P16	726-742
Q16	742-758
Q18	758-774
R23	774-787
R25	794-806
JB1	806-810
X9	925-932
J9	558-570



**SVX**

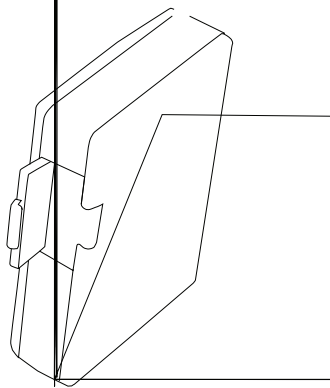





WACR

WASRM

WADRM

53A14226

95A14227

P12	698-710
P14	710-726
P16	726-742
Q16	742-758
Q18	758-774
R23	774-787
R25	794-806
JB1	806-810
X9	925-932
J9	558-570





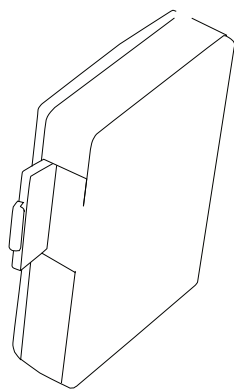

## Komponen Sistem

Semua Sistem

Bodypack Transmitter  
(Pemancar Bodypack)

Handheld Transmitter (Pemancar Genggam)

ATAU

Daya

Hubungkan ke Sound System (Sistem Suara).

Saluran

Penguatan Bodypack

Tingkat FR

Penindas

Gelang ID warna

# Mendapatkan Suara yang Bagus

## Penempatan Mikrofon yang Benar



Menggunakan Mikrofon Headworn

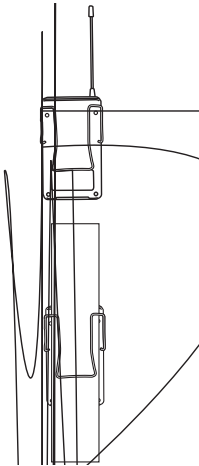



# Tip Wireles untuk Meningkatkan Kinerja Sistem

## Gangguan

Gangguan	Solusi
Tidak ada suara	
Kebisingan dari gangguan FR.	
Distorsi audio.	

# AKSESORI DAN SUKU CADANG

## Aksesori Opsional

Gelang Warna (6)	WACR
Kit Pemasangan Rak Saluran Tunggal	WASRM
Kit Pemasangan Rak Saluran Ganda	WADRM

## Suku Cadang Penggantian

Kunci Saluran	53A14226
Adaptor Penyangga Mikrofon	95A14227
Catu Daya PS21*	

\*Kunjungi distributor Shure setempat Anda untuk mendapatkan bantuan.

## Bagan Frekuensi

Gelombang	Jarak (MHz)
P12	698–710
P14	710–726
P16	726–742
Q16	742–758
Q18	758–774
R23	774–787
R25	794–806
JB1	806–810
X9	925–932
J9	558–570

### NOTE:

This Radio equipment is intended for use in musical professional entertainment and similar applications.

This Radio apparatus may be capable of operating on some frequencies not authorized in your region. Please contact your national authority to obtain information on authorized frequencies and RF power levels for wireless microphone products.

# SVX

Jarak Kerja	Mode daya HI: Mode daya LO:
Respon Frekuensi Audio	
Total Distorsi Selaras	
Rentang Dinamik	
Jarak Suhu Kerja	
Polaritas Audio Pemancar	

## SVX1

Tingkat Input Audio (maksimum)	Penyetelan MIKROFON:	Penyetelan SALURAN:
Jarak Pengaturan Penguatan		
Impedansi Input	Penyetelan MIKROFON:	Penyetelan SALURAN:
Daya Output RF		
Dimensi		
Berat		
Rumah		
Persyaratan-Persyaratan Daya		
Umur Bateri		

## SVX2

Tingkat Input Audio (maksimum)	
Impedansi Input	
Daya Output RF	Mode daya HI: Mode daya LO:
Dimensi	
Berat	
Rumah	
Persyaratan-Persyaratan Daya	
Umur Bateri	

## SVX4/ SVX88

Dimensi	SVX4:	SVX88:
Berat	SVX4:	SVX88:
Rumah		
Tingkat Output Audio		
J9 Tingkat Output Audio		
Impedansi Output	Konektor XLR: 6,35 mm (1/4") konektor:	
Sensitivitas		
Persyaratan-Persyaratan Daya	SVX4: SVX88:	



United States, Canada, Latin America, Caribbean:  
Shure Incorporated, 5800 West Touhy Ave, Niles, IL 60714-4608 USA  
Phone: 847-600-2000 Fax: 847-600-1212 (USA) Fax: 847-600-6446

Europe, Middle East, Africa:  
Shure Europe GmbH, Phone: 49-7131-72140 Fax: 49-7131-721414

Asia, Pacific:  
Shure Asia Limited, Phone: 852-2893-4290 Fax: 852-2893-4055